



THE WORLD'S FIRST  
**WATERPROOF CORDLESS  
SPECIAL OPS  
HAMMER DRILL**

(SO-HD-18-6Li-100)

## Functional Description and Specifications

### Intended Use

The Nemo Submersible Special Ops Hammer Drill is intended to drill tough materials such as cement, brick, blocks, or stone, and can be used underwater, in wet conditions, and on dry land.

### Packing List

Your Nemo Submersible Special Ops Hammer Drill is packaged together with the following accessories:

- ◆ (2) rechargeable 6 Ah Lithium-ion (Li-ion) battery packs
- ◆ Battery charger
- ◆ 2 spare chucks and extra chuck screws
- ◆ Hand pump
- ◆ Side handle and positioning ring
- ◆ Carrying case

## Technical Specifications

### Nemo Submersible Special Ops Hammer Drill

Model	SO-HD-18-6Li-100
Battery pack voltage	18V Li-ion
Battery cell specification	6Ah
No load speed (two speeds)	0 – 400 / 0 – 1500 RPM
No load IPM	0 – 17600 IPM
Maximum torque	345 in-lbs ( 39 Nm)
Chuck size	½ in ( 13mm )
Net weight (with battery)	10.35 lbs ( 4.69kg )
Working temperature	32-140°F ( 0-60°C )
Submersible up to	328 ft ( 100m )

### Battery Charger

Model	XVE-2100400
Approximate charging time	90 minutes
Charging output voltage	21V
Charging input voltage	100V – 240V



**Caution:** You must pressurize the Special Ops Hammer Drill before you can use it underwater, as described in *Pressurizing the Special Ops Hammer Drill for Underwater Use*, pages 13-14 .

## Safety Warnings



**Warning:** Read all safety warnings and instructions, and save them for future reference. Failure to adhere to these warnings can result in serious injury and damage to equipment.

### Work Area Safety

- ◆ All work should be done in accordance with the local, state, and government occupational safety and health guidelines.
- ◆ Keep your work area clean and well lit.
- ◆ Do not operate power tools in explosive atmospheres, such as in the presence of flammable liquids, gases, or dust.
- ◆ Keep bystanders away when operating power tools.

### Personal Safety

- ◆ Stay alert and use common sense when operating power tools. Do not use power tools when you are tired or under the influence of drugs, alcohol, or medication.
- ◆ Use personal protective equipment. It is recommended to always wear eye protection, as well as a P2 filter-class respirator.
- ◆ Dust from materials such as lead-containing coating, some wood types, minerals, and metal can be harmful to one's health. Observe the relevant regulations in your country for the materials to be worked.

## Power Tool Safety

- ◆ Store idle power tools out of reach of children and do not allow persons unfamiliar with the power tool or these instructions to operate the power tool.
- ◆ Maintain your power tools. Check for misalignment or binding of moving parts, breakage of parts, and any other condition that may affect the power tool's operation. If damaged, have the power tool repaired by an authorized service technician.



**Caution:** Under no circumstances should the power tool be opened for repairs or any other purpose by anyone other than an after-sales service technician authorized by Nemo Power Tools. Opening the power tool invalidates the manufacturer warranty.

- ◆ Use power tools, accessories, and tool bits in accordance with these instructions and in the manner intended for the particular type of power tool, taking into account the working conditions and the work to be performed. Consult local, state, and government occupational safety and health guidelines before operating a power tool.
- ◆ Switch off the power immediately if the tool bit jams. Be prepared for high reaction torque that can cause kickback. The tool bit can jam when the power tool is subject to overload, or if it becomes wedged in the workpiece.
- ◆ Hold the power tool with a firm grip. High reaction torque can briefly occur while driving in and loosening screws.
- ◆ Work only on secured, stable items. Do not hold any item to be worked on by the power tool in your hand. Secure the workpiece, clamped with clamping devices or in a vice, to ensure safety.
- ◆ Always wait until the power tool has come to a complete stop before placing it down. The tool bit can jam and lead to loss of control over the power tool.

## **Rechargeable Battery Safety**

- ◆ Use only the battery pack supplied with your power tool.
- ◆ When the battery pack is not in use, keep it away from other metal objects like paper clips, coins, keys, nails, screws, which can make a connection from one terminal to another.
- ◆ Store the battery pack only within a temperature range of 32°F - 113°F ( 0°C - 45°C ) .
- ◆ Before any work on the power tool, such as a tool change, as well as during transportation and storage, remove the battery pack from the power tool. There is danger of injury when accidentally activating the On/Off trigger.
- ◆ Do not open the battery.
- ◆ Protect the battery against heat, including continuous sun irradiation and fire.
- ◆ When the battery is defective, liquid can escape and come into contact with adjacent components.
- ◆ Use only original batteries with the voltage listed on the nameplate of your power tool. When using other batteries, such as imitations, reconditioned batteries, or other brands, there is danger of injury as well as property damage through exploding batteries.
- ◆ Use only the battery charger provided with the power tool to recharge the batteries. Only this battery charger is matched to the lithium-ion (Li-ion) batteries of your power tool.
- ◆ Protect the battery charger from rain and moisture. The battery charger is not waterproof.
- ◆ Do not charge other batteries. The battery charger is suitable only for charging the battery pack supplied with the tool.
- ◆ Before use, always check the battery charger, cable, and plug. If defects are detected, do not use the battery charger. Never open the battery charger. Instead, have it opened and repaired only by qualified personnel who will use original spare parts.

- ◆ If using the drill above water or in hot conditions, cool the tool down by dipping it in cool water regularly to prevent overheating.

## Getting Started with the Special Ops Hammer Drill

Your Nemo Submersible Special Ops Hammer Drill (SO-HD-18-6Li-100) includes the following main components:

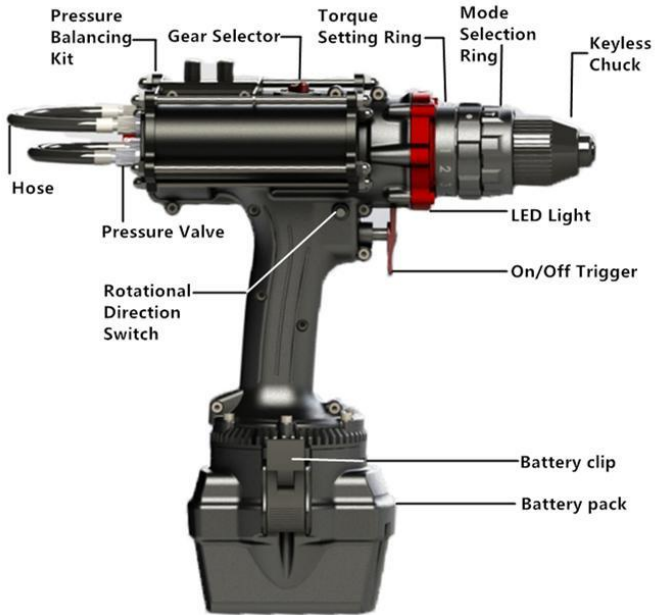

## Charging the Battery

The Li-ion batteries are supplied partially charged, and must be charged to full capacity using the battery charger provided with the hammer drill before using the hammer drill for the first time.



**Caution:** Only use the battery charger provided with the hammer drill. Only this battery charger is matched to the Li-ion batteries supplied with your power tool.



**Danger:** Ensure that the voltage of the power supply corresponds with the data given on the nameplate of the battery charger.



**Danger:** Only use the charger in a dry environment. The charger is not waterproof. Never attempt to charge the battery under water.

**Stock:** Make sure there is no metal or other things to block the connector after every dive and keep the brass pin dry when storing.

A battery can be charged at any time without reducing its service life. This is because the battery charger detects the charging condition of the battery, and charges it with the optimum current according to its temperature and voltage. This lengthens the battery life, and leaves it fully charged when stored in the charger. Interrupting the charging procedure does not damage the battery.

1. Connect the mains plug of the battery charger to an electrical outlet. A steady green light on the battery charger indicates that the charger is ready for operation.
2. Press the battery charger's connector into the socket on the top of the battery pack. There is only one way to insert the connector into the battery socket.



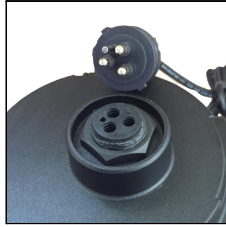

The battery begins charging as soon as it is connected to the charger.

- ◆ A steady red light on the battery charger indicates that the battery is charging.
- ◆ A steady green light on the battery charger indicates that the battery is fully charged.



**Note:** The battery is equipped with an NTC temperature controller that only allows it to be charged when its temperature is between 32° F - 113° F ( 0°C- 45°C ), ensuring a long battery service life.

3. When you are ready to use the battery, pull it vertically out of the charger.

### **Inserting a Battery in to the Special Ops Hammer Drill**

1. Ensure the 3-prong connector is in alignment with the 3 holes on top of the battery.
2. Insert the battery into the bottom of the drill base.



**Caution:** Use only a Li-ion battery from the original factory with the voltage listed on the nameplate of your drill. Using other batteries not suitable for the drill can lead to malfunctions, cause damage to the power tool, and pose a fire hazard.

3. Close the two plastic clips on the side to secure the drill into position.

## Removing a Battery from the Special Ops Hammer Drill

1. Unfasten the two plastic clips on the side..
2. Pull the battery pack out and down, without exerting any force.

## Inserting a Tool in to the Special Ops Hammer Drill

The hammer drill spindle is locked whenever the On/Off trigger is not pressed. This ensures quick, convenient and easy changing of the tool in the keyless chuck.

1. Set the rotational direction switch to the middle position.



**Caution:** To minimize the risk of accidental activation, always ensure the rotational direction switch is in the neutral (middle) position before performing any maintenance work on the hammer drill, as well as during transportation and storage.

2. Ensure that the On/Off trigger is not pressed.
3. Turn the chuck sleeve counterclockwise until it is open wide enough to fit the tool.
4. Insert the tool into the chuck, placing it as far as it will go.
5. Firmly tighten the chuck sleeve by hand, clockwise, to tighten the chuck.
6. To remove the tool, loosen the chuck sleeve counterclockwise until the tool is free.

## Replacing the Keyless Chuck

1. Set the rotational direction switch to the middle position.



**Caution:** To minimize the risk of accidental activation, always ensure the rotational direction switch is in the neutral (middle) position before performing any maintenance work on the hammer drill, as well as during transportation and storage.

2. The keyless chuck is secured with a securing screw to prevent it from unintentionally coming loose from the hammer drill spindle. Remove this screw by completely opening the chuck and unscrewing the screw, which has a left-handed thread, in a clockwise direction.
3. Remove the chuck as follows:
  - a) Place the hammer drill on a stable surface, such as a workbench.
  - b) Clamp the short end of an Allen key in the chuck.
  - c) Turn the Allen key counterclockwise to loosen the chuck.
  - d) Remove the Allen key from the chuck and completely unscrew the chuck by hand.
4. Mount a new chuck on to the hammer drill as follows:
  - a) Screw the chuck clockwise onto the hammer drill by hand.
  - b) Clamp the short end of an Allen key in the chuck.
  - c) Turn the Allen key clockwise to tighten the chuck to a tightening torque of approximately 177-221 inch pounds ( 20-25 Nm ).
5. Open the keyless chuck completely, and screw in the securing screw counterclockwise, to a tightening torque of approximately 35-44 inch pounds ( 4-5 Nm ).

## Connect the pressure balancing kit to the drill

1. Stand drill upright on a horizontal flat surface resting on its base.



2. Take the pressure balancing kit and place it on top of the Special Ops Hammer Drill. Align the two holes on the pressure balancing kit centre plate with the corresponding threaded holes on top of the drill. The pressure balancing kit should have the valve screw outlets facing the rear and both pressure cylinders should lie alongside the sides of the drill (not above it). Use the two bolts provided to secure the pressure balancing kit onto the drill.

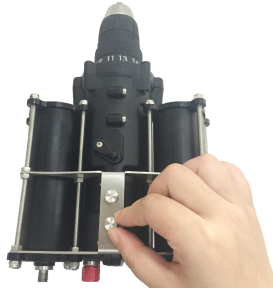

3. Unscrew the red valve cap (valve A) on the back of the drill and place to one side. Take Tube 1 and attach one end to the back of the drill where you have removed the red screw cap. Attach the other end to the right hand side outer screw (valve E). Tighten.



4. Take Tube 2 and attach one end to the right hand side inner screw (valve D). Connect the other end to the outer left hand screw (valve C). Connect the red pressure pump with valve B . Pump until desired pressure is reached.

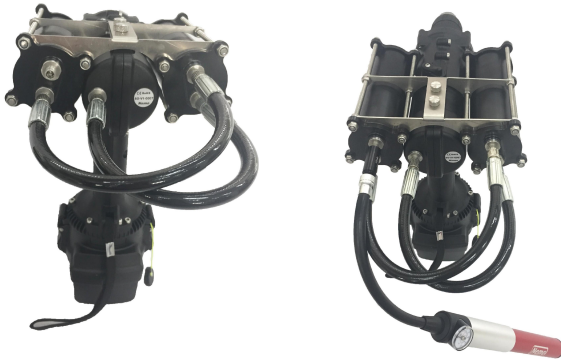

### **Pressurizing the Special Ops Hammer Drill for Underwater Use**

Your Special Ops Hammer Drill can be used in any wet conditions, and can be submerged and used underwater at depths of up to 328ft ( 100m ). Before submerging the hammer drill to any depth, it must be pressurized.

Pressurize the Special Ops Hammer Drill according to the depth to which you are going to submerge it, as follows:

Depth in meters	Depth in feet	Pressure
Up to 5m	16 feet	Minimum 15 psi ( 1 Bar )
Up to 10m	33 feet	Minimum 29 psi ( 2 Bar )
Up to 20m	66 feet	Minimum 44 psi ( 3 Bar )
Up to 30m	98 feet	Minimum 58 psi ( 4 Bar )
Up to 40m	131 feet	Minimum 72 psi ( 5 Bar )
Up to 50m	164 feet	Maximum 87 psi ( 6 Bar )
50m to 100m	164 feet to 328 feet	Maximum 87psi (6 bar) and make sure the pressure balance kit is working



**Caution:** Never add more than 87 psi ( 6 Bars ) of pressure to the Special Ops Hammer Drill. Meanwhile, You must release the pressure, after every dive.

## Best Practices for Underwater Operation

Your Nemo Submersible Special Ops Hammer Drill is designed to be waterproof, so that it can be used both on land and underwater. To obtain the maximum serviceable life of your hammer drill, adhere to the following best practices when using the hammer drill underwater:

- ◆ You must pressurize the hammer drill before you can use it underwater, as described in *Pressurizing the Special Ops Hammer Drill for Underwater Use*, pages 13-14.
- ◆ Do not exceed the maximum operational depth as recommended by the manufacturer.
- ◆ The Special Ops Hammer Drill is a hi-tech piece of equipment and should be treated with care. Its watertight seals may be damaged if it is dropped.
- ◆ When moving about or working underwater, the Special Ops Hammer Drill should be secured to you by a tool leash at all times.
- ◆ The Special Ops Hammer Drill can be used in salt water.



**Note:** After using the Special Ops Hammer Drill in salt water, immediately rinse it in fresh water to remove all salt residue.

- ◆ Before storing the Special Ops Hammer Drill in the carrying case after use in salt water, rinse it with fresh water and dry it off.
- ◆ Treat the high quality battery with care. Keep the battery fully charged and dry, ready for use, and always store it in the carrying case when not in use.



## Operating the Special Ops Hammer Drill

### Setting the Working Mode

The Special Ops Hammer Drill can function in regular drill mode, as a regular drill and driver, or in hammer mode. For more information, see *Performing Special Ops Hammer Drill Operations with the Special Ops Hammer Drill, page 20*, and *Performing Regular Drill Operations with the Special Ops Hammer Drill, page 20*.

1. Set the rotational direction switch to the middle position.



**Caution:** To minimize the risk of accidental activation, always ensure the rotational direction switch is in the neutral (middle) position before performing any maintenance work on the hammer drill, as well as during transportation and storage.

2. Do one of the following:
  - ◆ To work in regular drill mode, turn the mode selection ring until the three dots on the mode selection ring are aligned with the single dot on the middle ring.

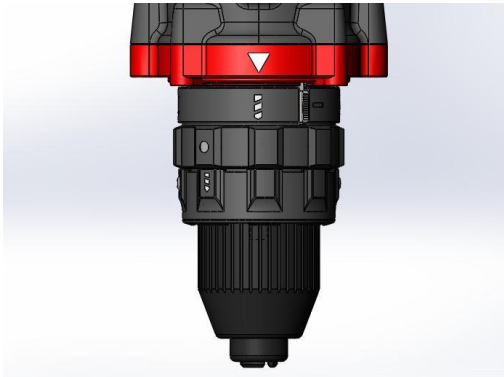

- ◆ To work in hammer mode, turn the mode selection ring until the hammer symbol on the mode selection ring is aligned with the single dot on the middle ring.

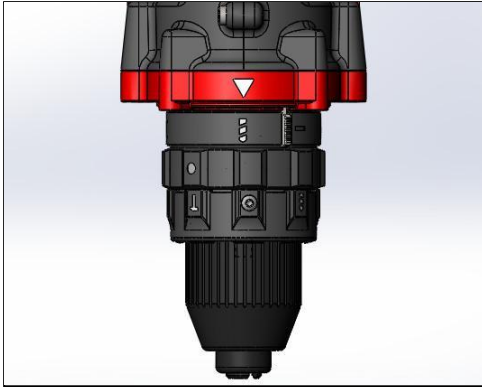

**Important:** Only use the Special Ops Hammer Drill in hammer mode when the torque is set to the maximum, and the hammer symbol on the mode selection ring is aligned with the single dot on the middle ring.

## Selecting the Torque

1. Set the rotational direction switch to the middle position.



**Caution:** To minimize the risk of accidental activation, always ensure the rotational direction switch is in the neutral (middle) position before performing any maintenance work on the hammer drill, as well as during transportation and storage.

2. Hold down the silver notch on the torque setting ring, then turn the torque setting ring until the desired torque setting is aligned with the triangle on the drill body. All three rings will rotate together as you turn the torque setting ring. If you select

the maximum torque (three dots), the silver notch pops out and locks.

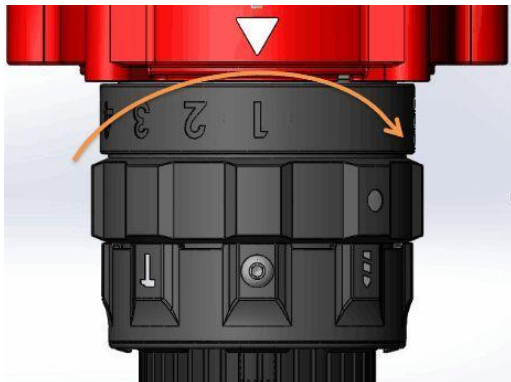

**Important:** Only use the Special Ops Hammer Drill in hammer mode when the torque is set to the maximum, and the hammer symbol on the mode selection ring is aligned with the single dot on the middle ring, as described in *Setting the Working Mode*, page 16 .

### Reversing the Rotational Direction

The rotational direction switch is used to control the rotational direction of the Special Ops Hammer Drill. The rotational direction can only be changed when the On/Off trigger is not pressed.

1. Ensure that the On/Off trigger is not pressed.
2. Do one of the following:
  - ◆ For drilling and driving in screws, push the rotational direction switch all the way to the left.
  - ◆ For loosening and unscrewing screws and nuts, push the rotational direction switch all the way to the right.
  - ◆ To deactivate rotation and only operate the LED flashlight, push the rotational direction switch to the middle, which is the neutral position.

## Selecting the Gear Speed

1. Set the rotational direction switch to the middle position.



**Caution:** To minimize the risk of accidental activation, always ensure the rotational direction switch is in the neutral (middle) position before performing any maintenance work on the Special Ops Hammer Drill, as well as during transportation and storage.

2. Do one of the following:

- ◆ Push the gear selector toward the keyless chuck to select low speed.
- ◆ Push the gear selector away from the keyless chuck to select high speed.



**Caution:** If the gear selector cannot be pushed all the way, lightly turn the chuck. The Special Ops Hammer Drill has a speed gear clutch, and the gear teeth sometimes hit together, causing the gear selector to stick. Turning the chuck releases the teeth and frees the gear selector. Do not force the gear selector when it is stuck, as this may break the gears.

## Switching the Hammer Drill On or Off

- ◆ Press the On/Off trigger, and keep it pressed. You can increase the speed of the hammer drill by increasing the pressure on the switch. To switch off the Special Ops Hammer Drill, release the On/Off trigger.



**Note:** When the On/Off trigger is not pressed, the spindle and the tool holder are locked. This allows the hammer drill to be used as a screwdriver, even when the battery is dead.

## Performing Special Ops Hammer Drill Operations with the Hammer Drill

Use the Special Ops Hammer Drill in hammer mode when drilling hard materials, such as concrete or stone.

1. Insert a tungsten-carbide tipped bit into the Special Ops Hammer Drill.
2. Position the tool tip against the workpiece, switch on the Special Ops Hammer Drill, and lightly press the tool tip against the workpiece. Excessive force will damage the tool tip and will not increase the drilling speed.
3. Hold the Special Ops Hammer Drill firmly to keep the drill bit from slipping away from the hole, and from jerking when it breaks through the workpiece or strikes reinforcing rods in concrete.
4. If the hole becomes clogged with debris, run the Special Ops Hammer Drill at an idle, then partially remove the drill bit from the hole. Repeat this action until the hole clears out.

## Performing Regular Drill Operations with the Special Ops Hammer Drill

Use the Special Ops Hammer Drill in regular drill mode when drilling relatively soft materials, such as wood, metal, or plastic.

1. Secure small workpieces using a vise or similar device.
2. Lightly press the tool tip against the workpiece. Excessive force will damage the tool tip and will not increase the drilling speed.
3. Hold the Special Ops Hammer Drill firmly and carefully as the bit begins to break through the workpiece.
4. If the drill bit gets stuck, release it by reversing the rotational direction.



**Note:** When drilling wood, use a guide screw to pull the drill bit into the workpiece for best results.



**Note:** When drilling metals, make an indentation at the point to be drilled to prevent the drill from slipping. For all metals other than brass and iron, use sufficient cutting lubricant during drilling.

## Maintenance

### Servicing the Special Ops Hammer Drill

If your Special Ops Hammer Drill is damaged or faulty, have it repaired by an authorized service technician.



**Caution:** Under no circumstances should the Special Ops Hammer Drill be opened for repairs or any other purpose by anyone other than an after-sales service technician authorized by Nemo Power Tools. Opening the Special Ops Hammer Drill invalidates the manufacturer warranty.

### Transporting the Special Ops Hammer Drill

For maximum protection, always transport your Special Ops Hammer Drill secured in its carrying case, with the battery removed.

The battery pack has effective protection against internal over-pressure and short-circuiting, as well as devices preventing violent rupture and dangerous reverse current flow.

The lithium-equivalent content in the batteries is below applicable limit values. Therefore, the batteries are not subject to national or international regulations pertaining to dangerous mediums, either as individual components or when inserted into a power tool.

However, the regulations governing dangerous goods may be relevant when transporting several batteries. In this case, it might be necessary to comply with special conditions, such as those governing packaging.

### Disposing of the Special Ops Hammer Drill

At the end of its lifecycle, the Special Ops Hammer Drill, its accessories, and packaging should be sorted for environmentally friendly recycling.

Do not dispose of the battery pack in household waste, fire, or water. Battery packs should be collected, recycled, or disposed of in an environmentally friendly manner.

### Troubleshooting Battery and Charger

<b>Problem:</b> The battery is not charging, and there is a blinking red light on the battery charger.	
<b>Possible Cause</b>	<b>Corrective Action</b>
The battery is not correctly inserted into the charger.	Remove the battery from the charger, then re-insert it correctly.
The battery contacts are contaminated.	Clean the battery contacts, for example by removing and inserting the battery several times, or replace the battery.
The battery is defective.	Replace the battery.

<b>Problem:</b> The battery charger indicator does not light up.	
<b>Possible Cause</b>	<b>Corrective Action</b>
The mains plug of the battery charger is not correctly plugged into the socket.	Insert the mains plug fully into the socket outlet, and ensure that the socket is functional.
The socket outlet, mains cable, or battery charger are defective.	Check the voltage power; have the battery charger checked by an authorized after-service agent.



**Caution:** Under no circumstances should the Special Ops Hammer Drill or accessories be opened for repairs or any other purpose by anyone other than an after-sales service technician authorized by Nemo Power Tools. Opening the Special Ops Hammer Drill invalidates the manufacturer warranty.

<b>Problem:</b> The battery charger is warm to the touch.	
<b>Possible Cause</b>	<b>Corrective Action</b>
Continuous or repetitive charging cycles without a break may cause the charger to warm up.	No corrective action is required as this does not indicate a fault with the battery charger.

<b>Problem:</b> The battery operation time is significantly reduced, even after the battery is fully charged.	
<b>Possible Cause</b>	<b>Corrective Action</b>
The battery is defective, or has reached the end of its life (approximately 1000 charging cycles).	Replace the battery.

<b>Problem:</b> The Special Ops Hammer Drill does not rotate.	
<b>Possible Cause</b>	<b>Corrective Action</b>
The rotational direction switch is in a neutral (middle) position, which operates only the LED light.	Push the rotational direction switch all the way to one side.
The battery has not been charged sufficiently.	Charge the battery and then try to use the Special Ops Hammer Drill again.



### **Battery Safety Feature**

A battery that " fails " or seems to have a short life before it shuts down , may simply be a battery that has gone into its SAFE mode .

A battery that has experienced an excessive current draw from a short circuit , or a high current draw when the tool was under an excessive load, may shut down prematurely . This is a built-in safety feature.

If the battery contacts are not damaged , recharging the battery for a short period ( even a few minutes ) will reset the battery's electronics and restore the battery voltage to the voltage level before it shut down.

If this battery or another battery experiences the same problem immediately upon restarting the tool , then a short circuit should be suspected and the tool should be inspected for needed repair .



Disclaimer :

Nemo Power Tools Ltd reserves the right to change the contents of this manual at any time without prior notice .

**Nemo Power Tools Ltd**  
**[www.nemopowertools.com](http://www.nemopowertools.com)**